

Effective Collaboration using Autodesk Revit Structure and Autodesk Building Systems

This white paper explains how structural engineers using Autodesk® Revit Structure software and mechanical/electrical/plumbing (MEP) engineers using Autodesk® Building Systems can improve their coordination and collaboration - using the DWG file format as well as the intelligent real-world objects from Building Systems to exchange design information, helping to ensure coordination and minimize conflicts between disciplines.

Revit Structure can produce DWG-based structural views that can be viewed by MEP engineers within Autodesk Building Systems. Alternatively, Revit Structure can export structural members as intelligent building objects native to Autodesk Building Systems that can be used directly in the Building Systems application.

Autodesk Building Systems also produces DWG-based building environmental system plans that can be viewed within Revit Structure. In addition, Autodesk Building Systems can export building objects as ACIS® geometry, allowing structural engineers to view the geometry of the building environmental systems directly in Revit Structure.

In this manner, structural and MEP engineers using Revit Structure and Autodesk Building Systems respectively can reference each other's designs for effective collaboration.

This paper describes the techniques, and provides additional considerations, relating to:

- Preparing and exporting 2D structural base plans from Revit Structure.
- Exporting a 3D Revit Structure model to Autodesk Building Systems.
- Referencing the Revit Structure design in Autodesk Building Systems.
- Exporting Building Systems designs to Revit Structure.
- Viewing Building Systems designs in Revit Structure.

CONTENTS

Exporting 2D
Structural Views to
Building Systems 2

Exporting 3D
Structural Models to
Building Systems 5

Using Structural
Views in Building
Systems 7

Exporting Building
Systems Designs ... 10

Viewing Building
Systems Designs in
Revit Structure 12

Exporting 2D Structural Views to Autodesk Building Systems

Structural engineers working with Revit Structure can export views of their structural project in DWG format for MEP engineers who are using Autodesk Building Systems - allowing the MEP engineers to reference the structural backgrounds during their design.

Revit Structure provides industry-leading DWG compatibility and can produce DWG deliverables just as AutoCAD® software can. Revit Structure supports a common process that most engineering firms use with their clients - producing well-organized and layered DWG files based on any layering standard the user desires.

Preparing a Revit Structure view for export is no different than preparing a drawing produced in an AutoCAD-based application: the structural engineer can simply turn off, freeze, or adjust the color of the appropriate layer prior to sending the drawing to the MEP engineer for use in Autodesk Building Systems.

Controlling Visibility in Revit Structure Views

To control the visibility of a structural design element, such as specific annotations, simply right click in the workspace area and select View Properties. The Element Properties dialog box for the view is launched.

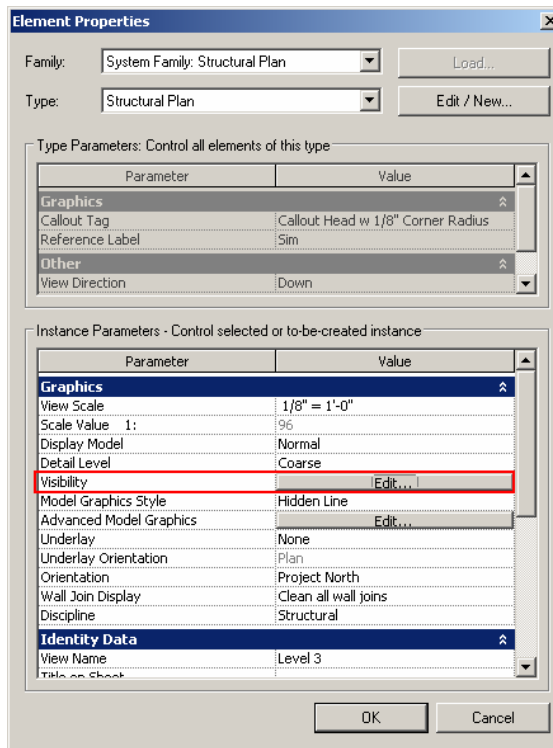

Figure 1

Structural engineers and drafters can filter the structural information they want to export to MEP engineers.

In the Element Properties, go to the Instance Parameters section, and click the Edit button next to the Visibility parameter. The Visibility/Graphic dialog box opens (Figure 2), which allows user to control the visibility and appearance of model, annotation, and imported elements.

For example, to turn off the visibility of structural rebar, select the Model Categories tab and uncheck Structural Rebar. To turn off structural rebar tags, select the Annotation Categories tab and uncheck Structural Rebar Tags.

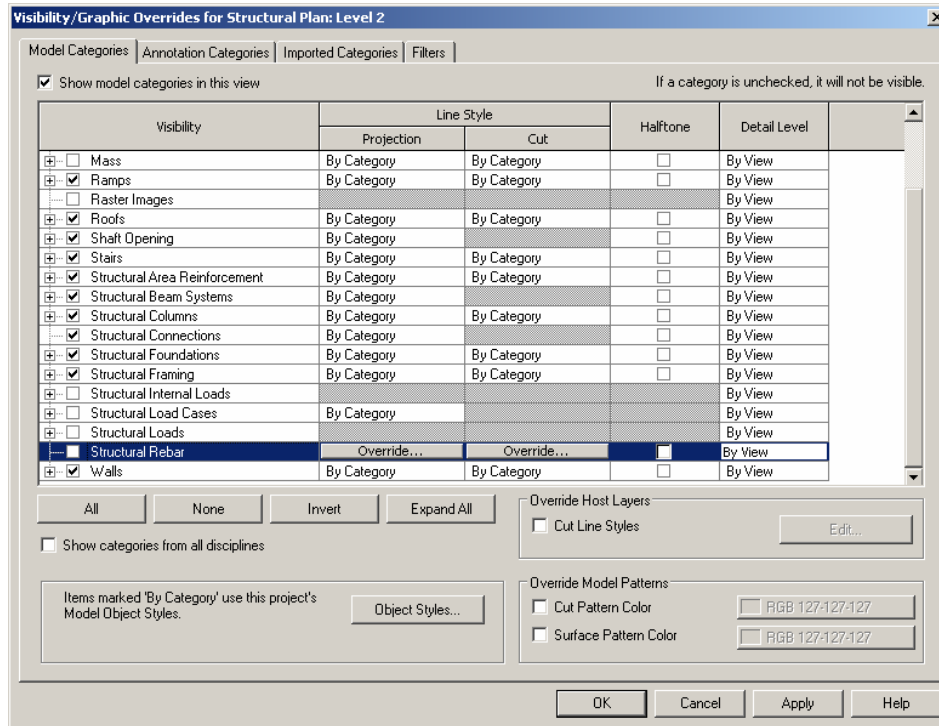

Figure 2

The visibility table allows a structural designer to turn on and off some structural objects and annotations, before exporting the view to a DWG format.

Note: Once an element is turned off in Revit Structure and exported in a DWG, its visibility cannot be turned on again by the Layer Manager of Building Systems.

Color Control in Revit Structure

Before exporting a Revit Structure view as a DWG, users should consider the desired layering scheme. Autodesk Revit Structure supports both local and international layering conventions with built-in AIA (US), BS1192 (UK), ISO 13567 (Europe), and CP 83 (Asia) formats.

Autodesk Revit Structure also supports custom layering conventions, offering a convenient mapping table that maps a Revit Structure design element directly to an appropriate AutoCAD layer name.

To access this layer mapping table, click File >> Import/Export Settings >> Export Layers DWG/DXF (Figure 3). Then using the Export Layers dialog box, Revit Structure categories and subcategories of components are mapped to a layer name and color ID for use in a DWG or DXF™ file (Figure 4).

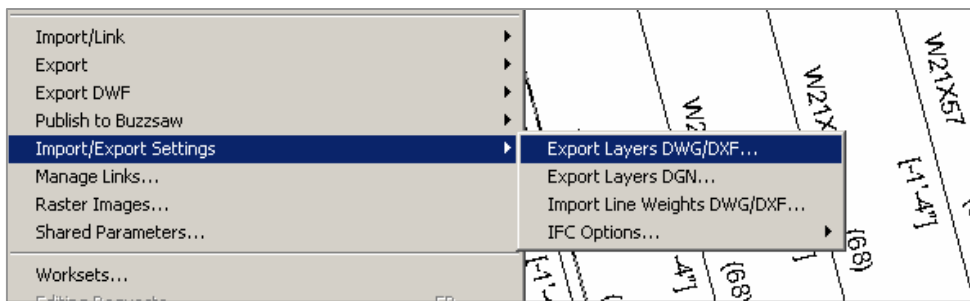

Figure 3

Although Revit Structure does not use layers, users can define a layering scheme when exporting a view to DWG format.

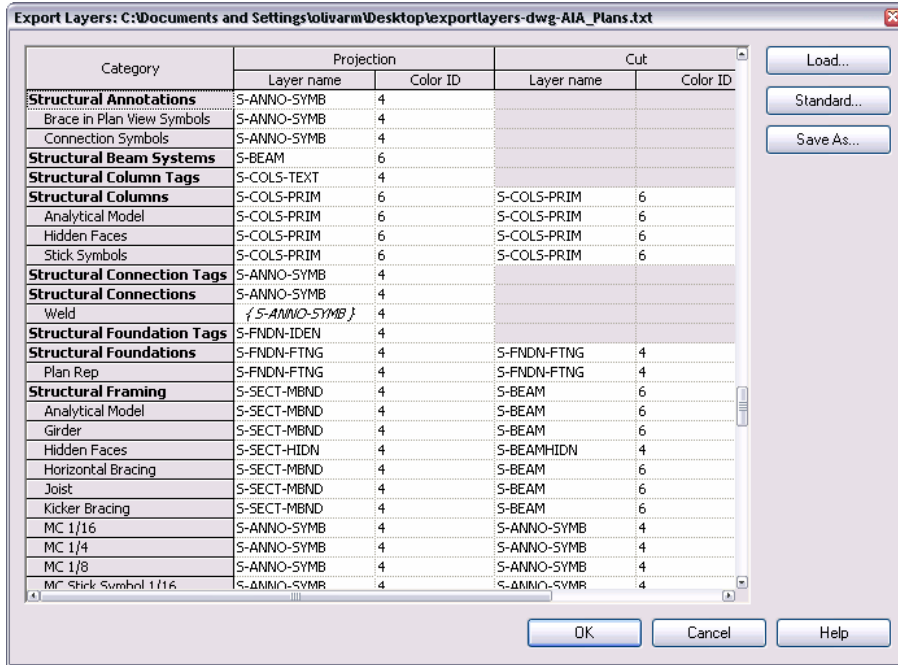

Figure 4

Each Revit Structure object category is associated to a layer and a color for projection or cut views.

Note: Revit Structure users who are planning on exporting views to an MEP engineer may want to create "export" copies of those views and prepare the copied view for export as described above. This "export" view can then be reused for future exports, so you will not need to repeatedly prepare views for export and then restore the view back to its original settings.

Example:

- Make a copy of the structural plan view for the first floor - renaming it "Structural floor 1 – for MEP".
- Set its View Properties accordingly for DWG export - adjusting the visibility and color of all the components, to suite the needs of the MEP engineer.
- Select an appropriate layering convention (could also be a copied Export Layer File), perhaps one that adheres to AIA layer naming conventions but is used just for exporting to Building Systems and all layers are set to gray (Color ID 8). See example in Figure 5, "ABS-exportlayers-dwg-AIA_Plans".

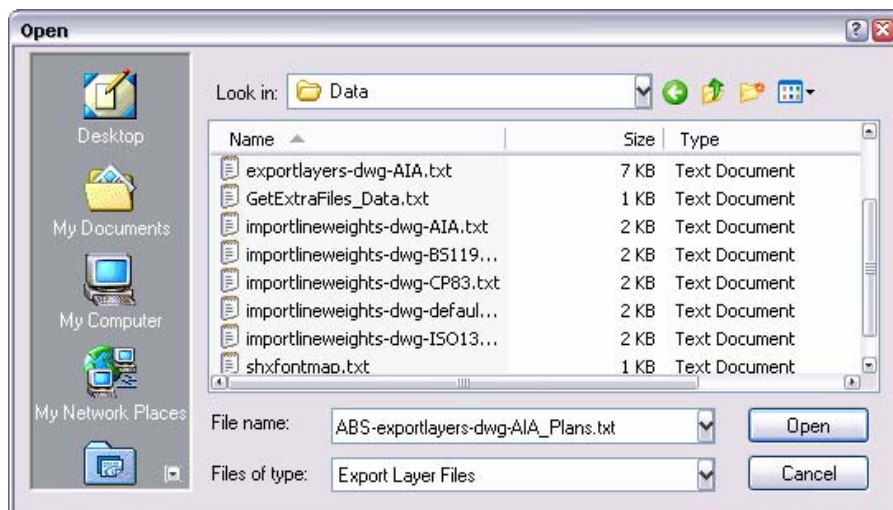

Figure 5

Export Layer Files allow structural designers to save layering conventions when exporting from Revit Structure.

Exporting Revit Structure Views as DWGs

Once the view has been prepared for export, select File >> Export >> CAD Formats.

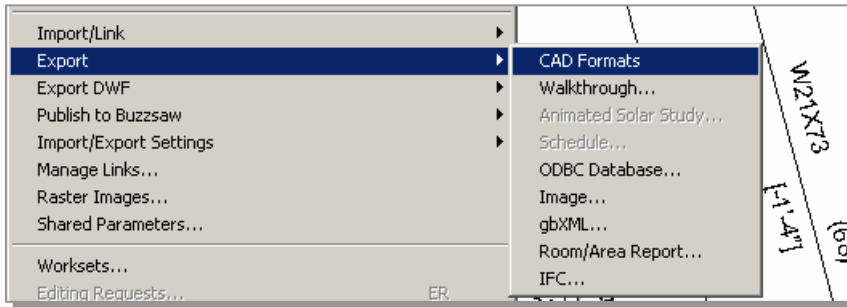

Figure 6

Revit Structure views can be exported to DWG format and the DWG files sent to the MEP design team.

Select a file name and location for the export file, as well as a file format. Revit Structure views can be exported to a variety of AutoCAD file formats depending on the software version required. Choose a layering scheme of the final DWG by selecting an existing standard or custom layering scheme. Users can also export multiple views all at once, such as the floorplan for each level, by changing the Export Range from Current View to Selected Views/Sheets.

Exporting 3D Structural Models to Autodesk Building Systems

For even better coordination with MEP engineers, Revit Structure exports structural components as intelligent building objects native to Autodesk Building Systems. Structural components in Revit Structure that are not of a type supported in Building Systems are exported as mass elements. Thus a complete structural model from Revit Structure (release 3) can be shared directly with MEP engineers who use are using Autodesk Building Systems (release 2007) – enabling the MEP engineers to check for interferences with structural elements directly inside their own Autodesk Building Systems environment.

Note: Revit Structure 3 only exports 3D structural models as true Building Systems objects in Autodesk Building Systems 2007.

Export Revit Structure Model

To export a Revit Structure model, select a 3D view of the building structure in Revit Structure, then select File >> Export >> CAD Formats. Specify a file name and location for the export file, and click on the Option button. In the Export Options dialog box, choose the option “Export as Architectural Desktop and Building Systems Objects” from the Solids pulldown menu.

Autodesk Building Systems does not support non-extruded structural members (coped elements, cutbacks, cuts, holes), which are supported in Revit Structure. Therefore, the Export Options dialog box also features the Prefer pulldown menu, which allows users to choose between exporting structural elements as Architectural Desktop objects (same as Building Systems objects) or exact geometry (mass elements without the structural properties). Revit Structure components that are not of a type supported in Building Systems (such as slabs, and footings with structural characteristics) are automatically exported as mass elements. For the non-uniform profiles, massing objects will also be created instead of the Building Systems structural member.

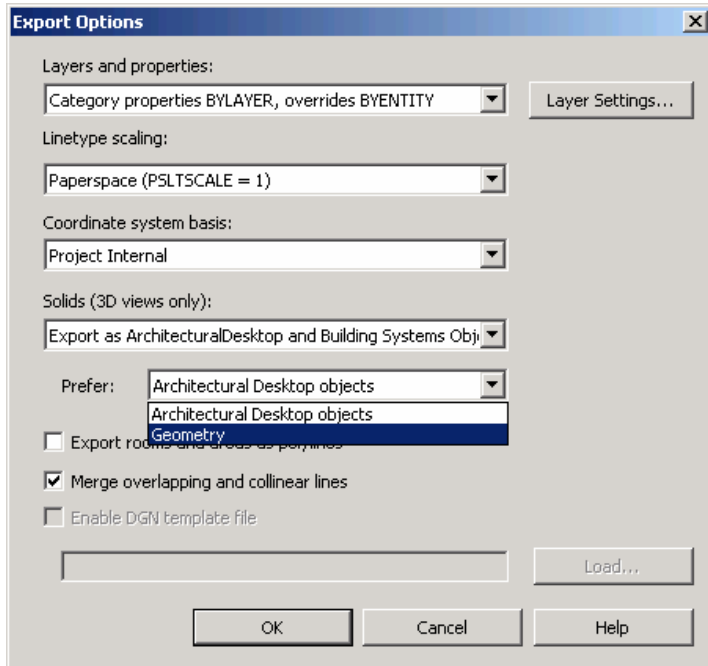

Figure 7

Structural engineers can export 3D Revit Structure components as native Building Systems (Architectural Desktop) objects or as massing objects (Geometry).

By selecting Architectural Desktop objects, users can export structural members as native Building Systems objects. This process creates simplified structural objects - losing some geometric accuracy but keeping the structural properties (such as section type = W12x40 for example). To preserve the exact shape of objects, users can select Geometry - resulting in massing objects which preserve the shape (of a coped beam for example) but lose the structural properties.

In addition, users can select whole family categories of structural elements to always be exported as geometry - keeping the exact geometry of the structure but losing the structural properties.

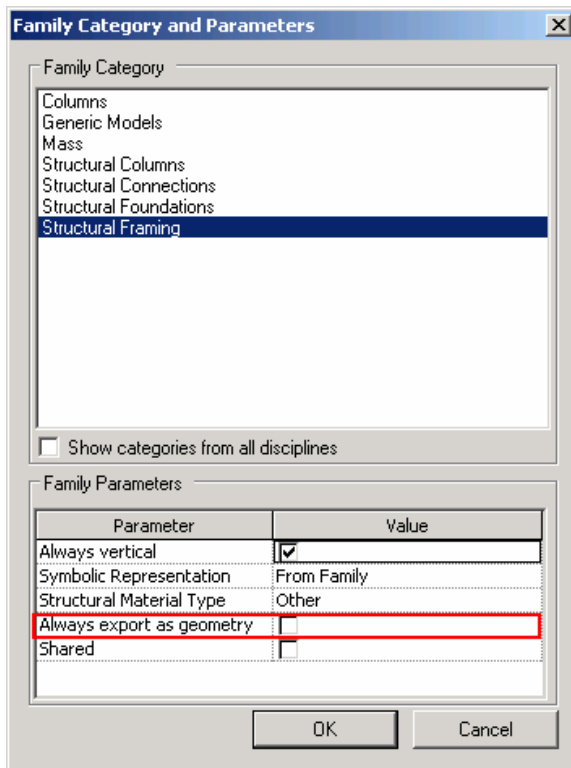

Figure 8

Structural engineers can select Revit Structure family categories that should always be exported as geometry.

Using Structural Views in Autodesk Building Systems

Bringing structural backgrounds from Revit Structure into Autodesk Building Systems can be done in a number of ways, based on how the MEP engineer typically works with Building Systems and manages drawing files. This section describes the process of using the drawing management features of Building Systems to work with structural backgrounds. [Note: for those Building Systems users who do not use drawing management features, the structural backgrounds are brought in as xrefs (linked files) and placed on their own individual layer - "Struc-Base" for example].

To associate a structural plan to the current MEP project, in Building Systems open the structural drawing file exported from Revit Structure. Use the following steps to save the drawing as a Construct in the current project:

- Open the Project Navigator.
- Go to the Constructs Tab and right-mouse-click on the Constructs Category to access Save Current DWG as Construct.
- In the Add Construct dialog box, name the drawing and give it a description.
- Finally, associate the drawing to a floor (for example, if the structural plan is for the 1st floor, select Level 1).



Figure 9

Exported structural views are saved as Constructs in Autodesk Building Systems.

Note: For ease of organization, MEP engineers typically create a folder to place all of the structural backgrounds prior to adding the drawing as a construct file.

Once the structural drawing is associated with the project, a user can begin to coordinate the system designs to the structural components of the building (which are now attached as an xref).

Best practices suggest that users should attach the structural plan drawing as an Overlay in the current design. For example, when working on an HVAC layout for the 1st floor, open the appropriate construct in the Project Navigator.

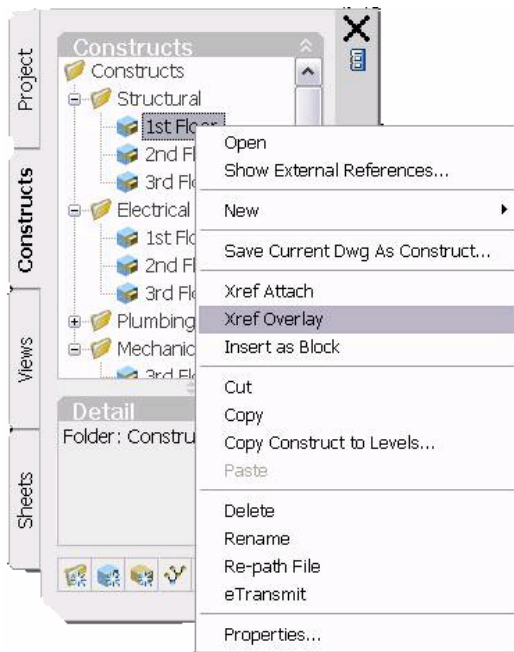

Figure 10

Attaching structural drawings as Overlays allow them to be managed by the Xref Manager.

Note: Attaching an xref using the Project Navigator will automatically place the structural base drawing on the 0 layer. To change this layer, modify the properties of the base drawing's layer.

Still using the Project Navigator, right-mouse-click on the structural plan drawing of the same level and select Xref Overlay. Now the structural plan drawing has been automatically xref'd into the current design and can be managed through the Xref Manager.

Managing Structural Base Drawing Updates

There are two methods for updating structural plan drawings, based upon the access of the MEP and structural users to a shared network:

- If both applications have access to the same directories, the structural engineer using Revit Structure can overwrite the structural base drawing in Autodesk Building Systems by saving the update in the appropriate folder.
- If both applications do not have access to the same directories, the MEP user must update the structural plan manually by placing the newer version of the drawing in the appropriate folder.

The xref notification feature in Autodesk Building Systems will automatically notify those using a specific structural base drawing that it has been updated when the drawing is opened or in use.

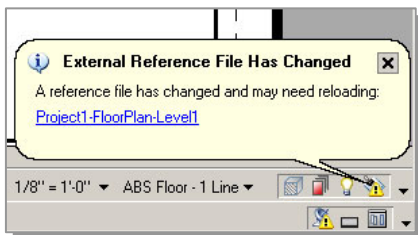

Figure 11

An xref notification alerts users that a drawing file has been

Note: To take advantage of the xref management notification functionality, set the Xref Notification update to one minute intervals by typing (setenv "XNOTIFYTIME" "1") on the Command Line.

Checking for Interferences in Autodesk Building Systems

In Autodesk Building Systems, the MEP engineer can use the Collision Detection feature to check for interferences between an MEP system layout and the structural plans referenced from Revit Structure - a critical aspect of effective collaboration between disciplines on projects.

Once the 3D structural model has been referenced into the Building Systems project, turn on the Collision Detection alert option by opening the Options dialog, selecting the ABS Layout Rules tab, and in the Collision Detection section, check the Alert option (Figure 11, top). Users can also change the color used to highlight collision (default color is red).

Click OK and the drawing automatically regenerates to display any collisions (indicated by the red arrow in Figure 11, bottom). Autodesk Building Systems can detect collisions between Building Systems objects (two ducts colliding or a duct and a pipe for example) as well as between Building Systems objects and structural members from the exported Revit Structure model.

Note: Collision detection between Building Systems objects and object-based structural members exported from Revit Structure 3 is supported only in Autodesk Building Systems 2007.

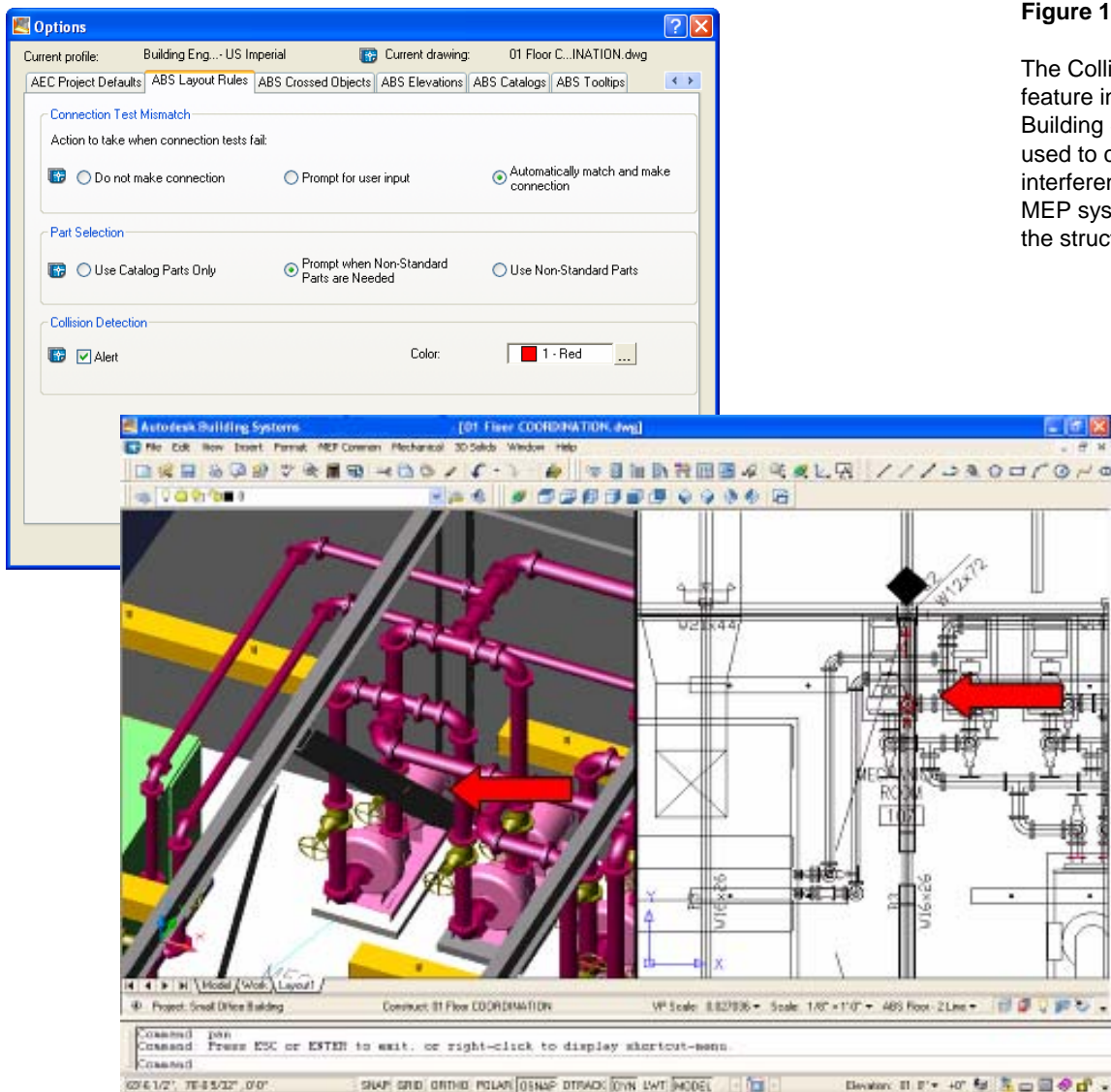

Figure 12

The Collision Detection feature in Autodesk Building Systems can be used to check for interferences between an MEP system layout and the structural plans.

Exporting Autodesk Building Systems Designs to Revit Structure

The first step in linking an Autodesk Building Systems MEP design to a Revit Structure project is to use the Export to AutoCAD functionality included within Building Systems. This feature saves all design data as AutoCAD entities (such as lines, circles, arcs, and blocks), which can then be read and understood by Revit Structure.

Creating a Design with both 2D and 3D Views

Autodesk Building Systems, through its use of intelligent objects, automatically creates 2D and 3D representations of the MEP designs which can be viewed by other AutoCAD-based applications, as well as Revit Structure.

Use the following steps to create an Autodesk Building Systems drawing with both a 2D and 3D display for use in Revit Structure:

1. With the MEP design open in Building Systems, create a new layout and then two viewports.
2. In one of the viewports, set the view to Plan. Use the built-in display configurations of Building Systems to set the view to either 1-Line or 2-Line.
3. Set the second viewport to an Isometric view.
4. With the layout page still current, use the Export to AutoCAD feature.

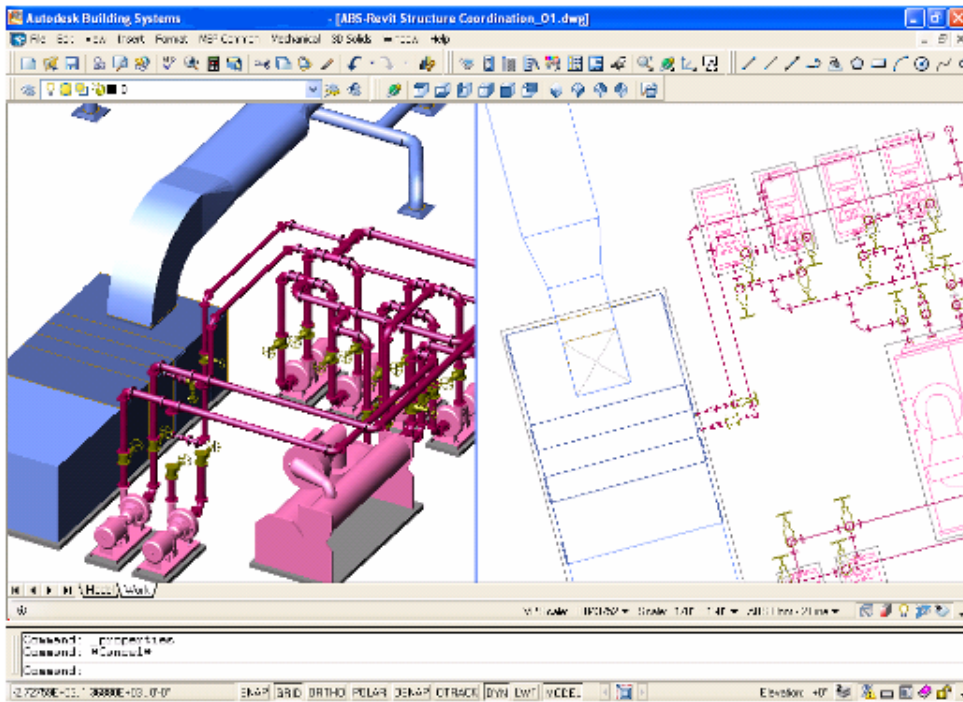

Figure 13

Use the Export to AutoCAD feature in Autodesk Building Systems to export an MEP design for use in Revit Structure.

Note: The Export to AutoCAD feature exports all linework/objects in the Building Systems drawing, regardless where the linework/objects reside. Therefore, before using the Export to AutoCAD feature, detach the external reference of any structural floor plan. This will enable only the Building Systems data to be exported.

The exported file contains two block representations in model space; one in 2D and the other in 3D. These blocks represent the Display Configuration Views that were currently active in each viewport of the layout prior to export. Furthermore, each block representation is on its own layer (named for the layout viewport) as well.

When linking this file into Revit Structure, users can control the appearance of the floor plan and 3D views by working with the visibility of these layers.

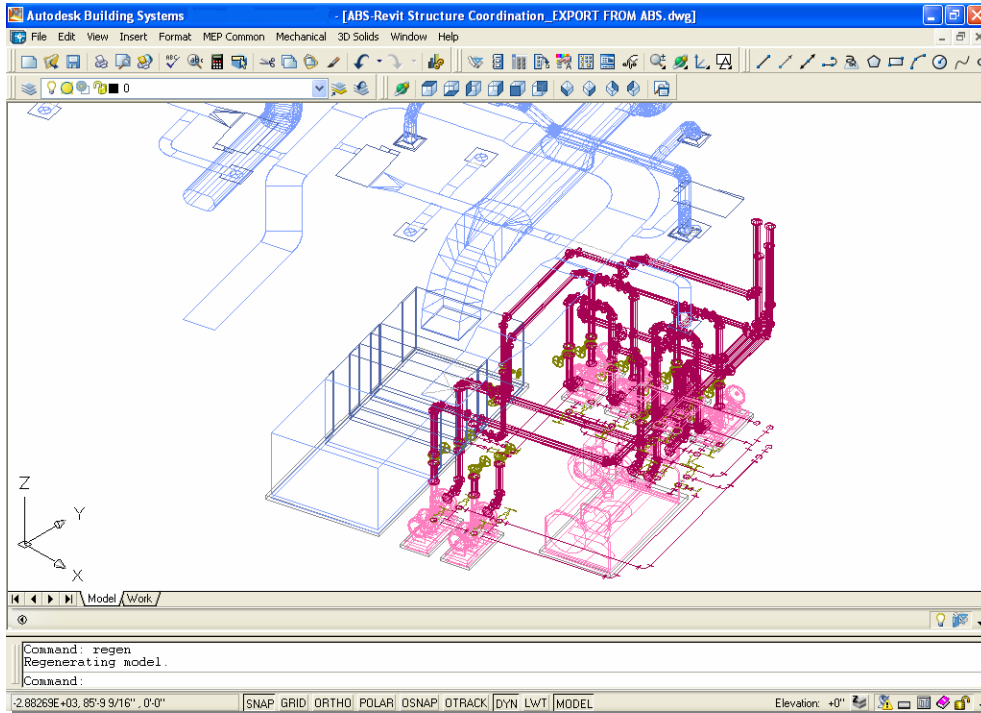

Figure 14

The exported file contains the 2D and 3D representation of the MEP design in model space.

Viewing Autodesk Building System Designs in Revit Structure

To add an Autodesk Building Systems drawing into a Revit Structure project, first the user must link the MEP drawing to the appropriate Revit Structure view. Begin by opening the Import/Link dialog box by selecting File >> Import/Link >> CAD Formats.

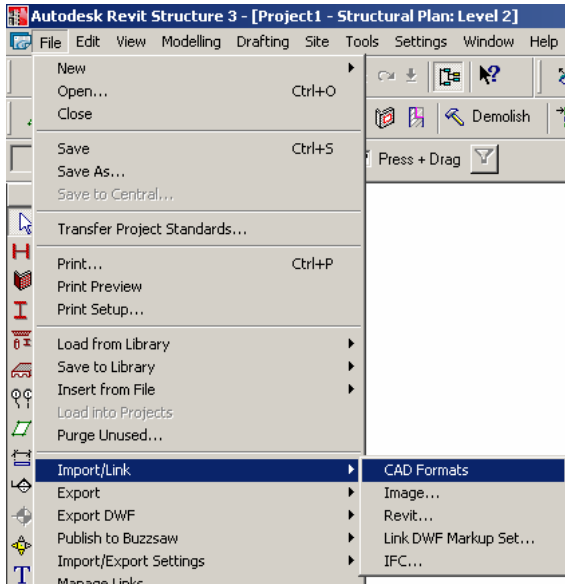

Figure 15

Before using an Autodesk Building Systems design in Revit Structure, it must be linked to the Revit project.

In the Import/Link dialog box, browse to the drawing and select it. Use the Origin-to-Origin option in the Position section to align everything properly. To have access to the layer structure from the drawing file, verify All is selected for Layers in the Import or Link section.

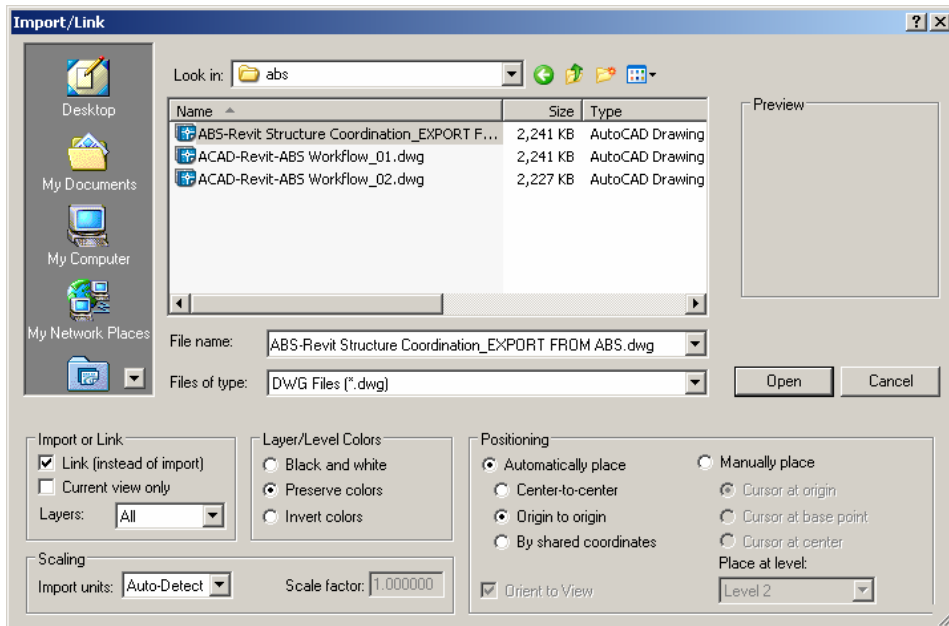

Figure 16

The Import/Link dialog box in Revit Structure offers various options for linking a document created externally.

Setting Appropriate Building Systems Views in Revit Structure

Since the newly linked Autodesk Building Systems model has both 2D and 3D displays, users should turn off the visibility in each view accordingly.

In order to make sure that only the 2D representation of the MEP design is visible in the floor plan view, turn off the visibility of the “3D” layer in the plan view. In the view's Visibility/Graphic dialog box, click on the Imported Categories tab, expand the drawing name to expose all of the layer names and uncheck the first Viewport name, "AecObjexplode_Work_Vport_A1A" in this example (Figure 17, top). The structural plan view now only shows the 2D MEP representation (Figure 17, bottom).

Note: Viewport Layer names are created automatically when the Export to AutoCAD feature is used in Autodesk Building Systems. In Revit Structure, these layer names are listed by the order of their appearance on the Layout Sheet. In the example used here, the first Viewport contained the 3D view. Therefore, this is the Viewport Layer name that should be turned off in the Revit Structure plan view.

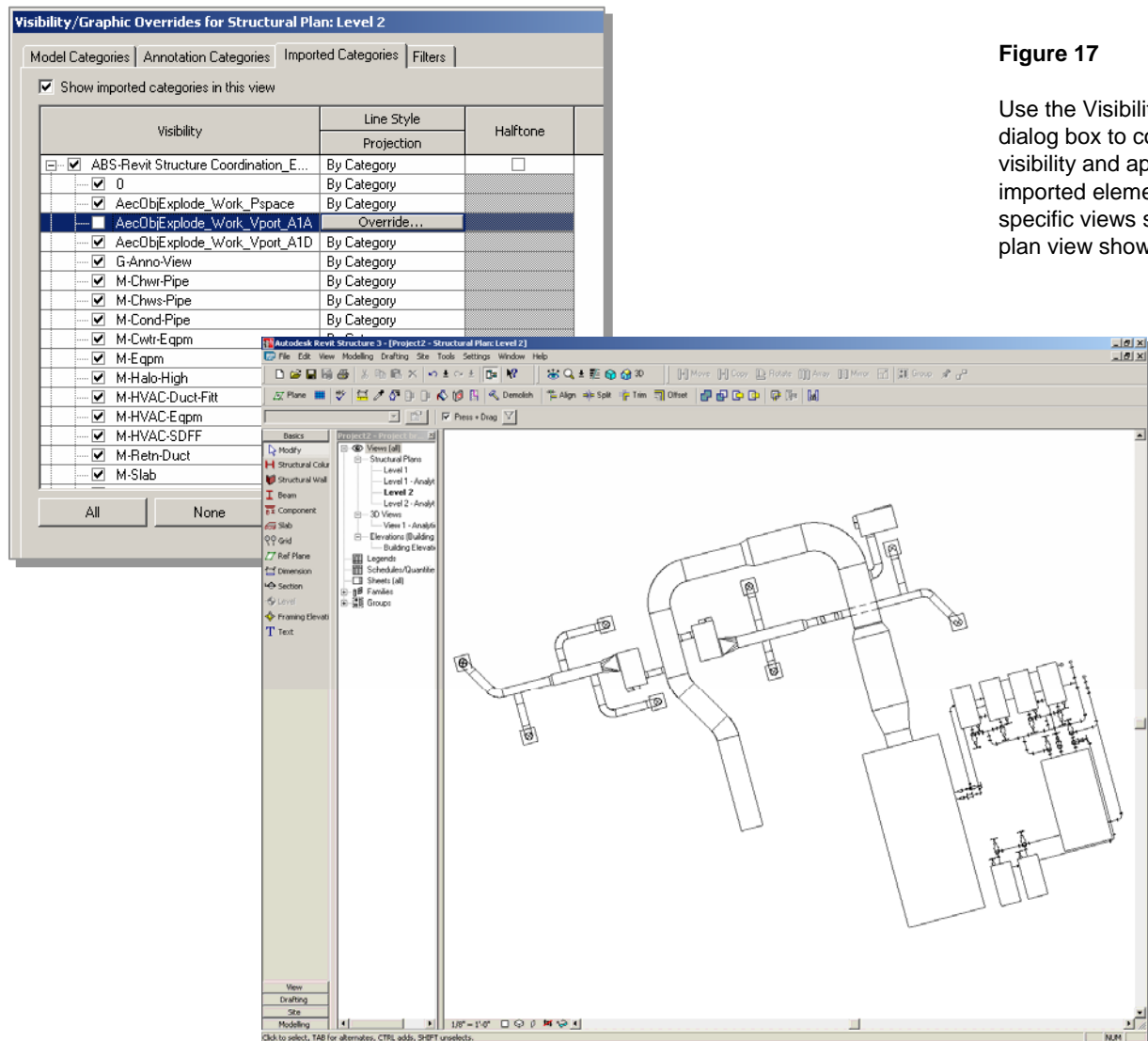

Figure 17

Use the Visibility/Graphic dialog box to control the visibility and appearance of imported elements in specific views such as the plan view shown here.

Use a similar procedure to turn off the 2D MEP representation in a 3D view:

- Uncheck the second Viewport in Visibility/Graphics to turn off the 2D display and check the first Viewport to turn the 3D display back on (see Figure 18).
- The 3D view updates - the 2D representation is turned off, leaving only the 3D representation visible (see Figure 19).

<input checked="" type="checkbox"/>	ABS-Revit Structure Coordination_E...	By Category
<input checked="" type="checkbox"/>	0	By Category
<input checked="" type="checkbox"/>	AecObjExplode_Work_Pspace	By Category
<input checked="" type="checkbox"/>	AecObjExplode_Work_Vport_A1A	By Category
<input type="checkbox"/>	AecObjExplode_Work_Vport_A1D	By Category

Figure 18

The Visibility/Graphics dialog box shows all the layer names of imported Viewports.

Note: When the Export to AutoCAD feature is used, a unique Viewport layer name is automatically generated each time. Revit Structure users who need to control the visibility of the 2D and 3D MEP representations should open the exported drawing in Building Systems, select the 2D and 3D block, and make note of the layer name and the blocks on that layer.

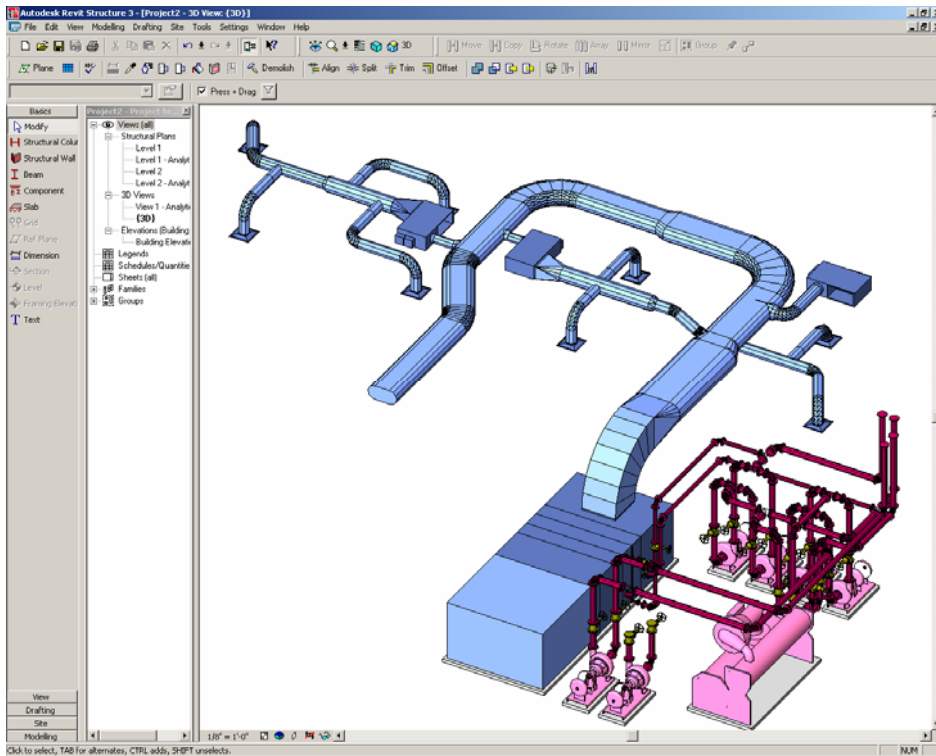

Figure 19

The imported 3D representation of the MEP design is displayed in 3D views of Revit Structure.

Note: The Visibility/Graphics dialog box can also be used to control the appearance of other MEP design elements. Since Building Systems automatically places its design objects based on user-defined layer standards, users can go to the appropriate view in Revit Structure and find the layer name of individual components of the block by using the Query tool. Once the layer name is known, return to the Visibility/Graphics menu to turn on or off blocks of MEP elements (HVAC equipment or chilled-water return piping, for example).

Bringing up both the floor plan and the 3D views side-by-side, along with the structural layout, the user can see the complete MEP design in Revit Structure.

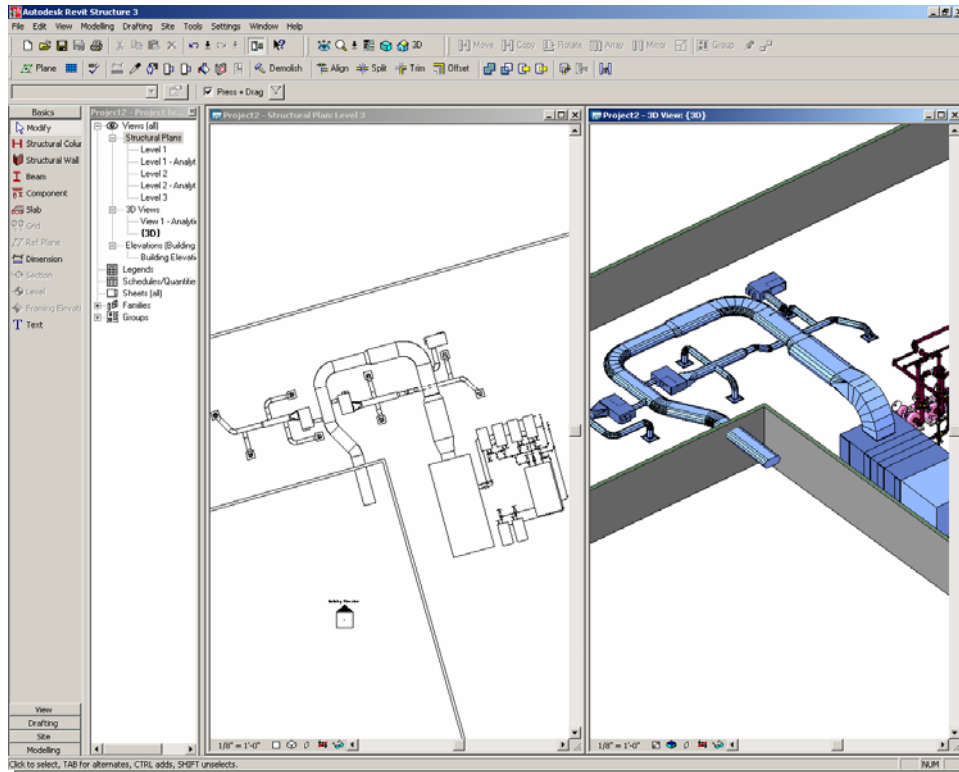

Figure 20

The imported 2D and 3D representations of the MEP design are both displayed within Revit Structure.

Note: Linked drawings from Building Systems cannot be modified in Revit Structure. Changes (or section cuts) must be made in Building Systems and the initially linked file must be overwritten by the Export to AutoCAD feature. This file must then be re-linked in Revit Structure using the Manage Links feature.

Summary

As described in this white paper, Autodesk Revit Structure is fully interoperable with Autodesk Building Systems - improving the coordination and collaboration between structural engineers and MEP engineers.

This collaboration allows both parties to make better informed project decisions, and their enhanced ability to coordinate their respective designs increases the quality of their final project deliverables to building owners and constructors.

About Autodesk Revit

The Autodesk Revit platform is Autodesk's purpose-built solution for building information modeling. Applications such as Autodesk Revit Building, Autodesk® Revit® Structure, and Autodesk® Revit® Systems built on the Revit platform are complete, discipline-specific building design and documentation systems supporting all phases of design and construction documentation. From conceptual studies through the most detailed construction drawings and schedules, applications built on Revit help provide immediate competitive advantage, better coordination and quality, and can contribute to higher profitability for architects and the rest of the building team.

At the heart of the Revit platform is the Revit parametric change engine, which automatically coordinates changes made anywhere — in model views or drawing sheets, schedules, sections, plans... you name it.

For more information about building information modeling please visit us at <http://www.autodesk.com/bim>. For more information about Autodesk Revit and the discipline-specific applications built on Revit please visit us at <http://www.autodesk.com/revit>.



Autodesk, AutoCAD, DXF, and Revit are registered trademarks or trademarks of Autodesk, Inc., in the USA and other countries. All other brand names, product names, or trademarks belong to their respective holders. Autodesk reserves the right to alter product offerings and specifications at any time without notice, and is not responsible for typographical or graphical errors that may appear in this document. Computer aided design software and other technical software products are tools intended to be used by trained professionals and are not substitutes for your professional judgment.

© 2006 Autodesk, Inc. All rights reserved.