

Making the Leap

from AutoCAD to Autodesk Inventor



10 Easy Steps from
CADENCE Magazine Columnist
Lynn Allen



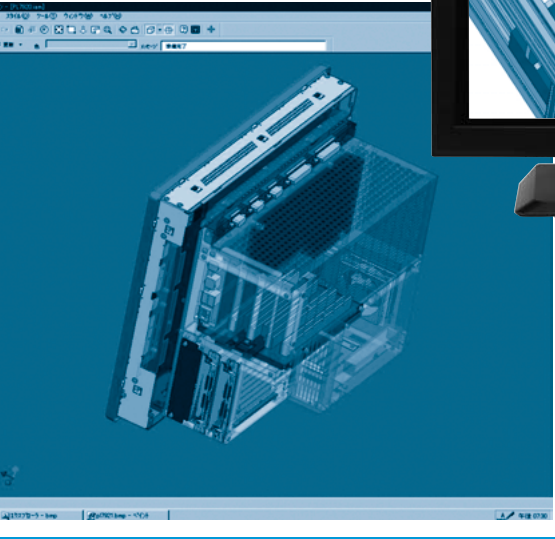



Making the Leap from AutoCAD to Autodesk Inventor

So here I am, one of the biggest fans
of AutoCAD[®], writing a booklet
on Autodesk Inventor[®].

Why would I want to do that?

Well, I must admit I was skeptical at first that this 3D modeling product could really be as easy and powerful as everyone said it was, not to mention the fact that Autodesk Inventor isn't even based on AutoCAD! What about all those years of AutoCAD knowledge I've acquired? How could I possibly draw faster in any other CAD package than I do in AutoCAD? In this booklet, I hope to convince you that, believe it or not, it's actually easier (and faster!) to draw in 3D Autodesk Inventor than it is in 2D AutoCAD. I'm a believer, and I hope to turn you into one as well.

This booklet is intended to be an easy read and a friendly introduction to the world of Autodesk Inventor. Delivered in 10 easily digestible doses, it covers the basics in a way that I hope makes you feel comfortable taking your first steps into this robust and exciting 3D modeling package. You'll even discover that if you aren't ready for the world of three dimensions yet, Autodesk Inventor is an amazing 2D program as well. The parametric modeling capabilities in Autodesk Inventor kick the IQ of the program up so many notches you'll find that it does much of the work for you! In fact, Autodesk Inventor is so smart and so easy to use that you'll keep thinking there must be a catch (I certainly did!). There's no catch—it's just a remarkable program that's built on tomorrow's technology. And why shouldn't it be? It's written by the company you've trusted with your designs for over 20 years—Autodesk!

So let's begin our journey into the world of Autodesk Inventor software...



1 Discover the Difference Between AutoCAD and Autodesk Inventor

A



B



There are many differences between AutoCAD and Autodesk Inventor software. We're going to take a look at five of the biggest and most apparent differences between the two products to make sure we're off to a good start.

A AutoCAD is "geometry-driven design"; Autodesk Inventor is "dimension-driven design."

In AutoCAD, we create our geometry and then place our dimensions. If we make changes to the existing geometry, the associated dimensions update (hopefully!). Wouldn't it be nice if you could change the value of the dimension and drive the shape and size of the part?

Well, that's exactly how Autodesk Inventor works. You roughly sketch the part you want to create, and then you control the exact size and shape of the part with dimensions. Imagine how easy it would be to make changes to your part later by simply changing the dimension values. Need to change the length of a plate from 30 mm to 35 mm? Simply change the dimension! Why does Autodesk Inventor work this way and AutoCAD does not? Autodesk Inventor has the added intelligence of being a parametric modeler.

Autodesk Inventor is a feature-based modeler.

As you create your 3D parts, each extrusion, hole, chamfer, fillet, and so forth, is stored as an independent feature in the Autodesk Inventor browser. This makes it extremely easy to make changes down the road. If you decide that

hole should have been 10 mm instead of 12 mm, it's not a problem to make the change. In AutoCAD we often find ourselves deleting and re-creating a specific feature. Such changes in Autodesk Inventor are as easy as changing the dimension value.

Autodesk Inventor supports adaptivity.

One of the features that separates Autodesk Inventor from other 3D modelers is the ability to create adaptive parts. These smart parts maintain a physical relationship so that if you modify the geometry of the base part, the adaptive geometry knows to update as well. This could be as simple as creating a hole that adapts to the size of a rod. As you change the size of the rod, the hole gets larger or smaller to accommodate the new diameter of the rod.

Autodesk Inventor doesn't use layers!

There, I said it—and if you can handle that concept, you're a prime candidate to learn Autodesk Inventor. Let's face it, none of us really likes dealing with layers in AutoCAD, but we're forced to because of linetypes, lineweights, and so on. What if you could set up all your parameters once and have Autodesk Inventor automatically assign them to your parts from that point forward? Let the software do those tedious chores for you so you can focus on the important aspects of your design.

Autodesk Inventor was built specifically for the manufacturing industry.

AutoCAD was built (nearly 20 years ago) to be all things to all people. It must take into consideration the needs of all disciplines: AEC, Civil, FM, Plant Design, and so forth. Autodesk Inventor was created with one and only one industry in mind—Manufacturing. From the ground up, Autodesk Inventor was built to think the way you think and act the way you expect it to act.

Last but not least—repeat after me—Autodesk Inventor is not AutoCAD! You will have a much happier life if you realize this early on and don't try to equate the AutoCAD world and processes to Autodesk Inventor technology.



2

Get Comfortable with Autodesk Inventor

A



B

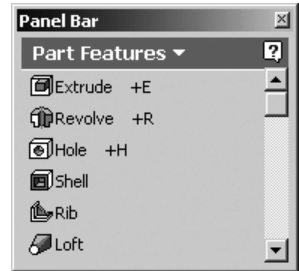

First and foremost, you need to feel comfortable in the Autodesk Inventor environment. Let's take a quick tour of the user interface and point out some of the similarities with and differences from our familiar AutoCAD environment.

A What happened to my command line?

We depend on it in AutoCAD. In fact, to some of us it's practically a religion, but in Autodesk Inventor you won't even miss it. We don't use "commands" in Autodesk Inventor, we use "tools." You can easily access each tool from four different areas—pull-down menus, toolbars, context-sensitive shortcut menus, and the panel bar. Of these, only the panel bar should be unfamiliar to you. While AutoCAD still relies on countless keyboard options for many commands, here you'll find a variety of friendly, dynamic dialog boxes to input data. A message segment of the Standard toolbar helps guide you along, but it does not accept input like the AutoCAD command line does. You'll also find that the status bar located in the lower left corner of the screen often contains pertinent information.

B What is a panel bar?

Imagine if AutoCAD were smart enough to display the appropriate toolbar, depending on where you were in your design process. If you were dimensioning, the Dimensioning toolbar would automatically appear. If you were editing your drawing, the Modify toolbar would appear, and so forth. Well, Autodesk

Inventor is smart enough to supply you with the tools appropriate for the particular mode you are in. On the left side of the screen (by default), you'll find the panel bar acts much like an intelligent toolbar. If you are sketching in 2D, the panel bar displays the 2D tools. When you are ready to turn your 2D sketch into a 3D feature, the panel bar switches to display your 3D tools. You spend less time looking for commands and more time focusing on the design.

How do I use the Autodesk Inventor browser?

In the lower left corner of the screen, a browser panel displays a history of how your geometry was created. As you select the items in the browser, you'll find that the designated geometry highlights on the screen. It's easy to edit your file by selecting the desired geometry from the browser. In AutoCAD we select our geometry by using the Crossing and Standard Window selections (which, incidentally, also works in Autodesk Inventor). You'll find that the browser is a nice addition for selecting those hard-to-reach parts.

What happened to my UCSICON?

The UCSICON has been replaced with a color-coded 3D indicator. The red arrow indicates the X direction, green indicates the Y direction, and blue indicates the Z. We're extremely dependent on the UCSICON in 3D AutoCAD, but in Autodesk Inventor I think you'll find your reliance on the 3D indicator is minimal.

You can turn on a variety of snap and grid settings as well as an origin point if that makes you feel more comfortable. In fact, if you insist on using coordinates while drawing, you can turn on Precise Input (but I'll try to talk you out of that).

Take a spin through this simple and logical user interface—it won't take long for you to feel right at home in the Autodesk Inventor environment.



3

Learn to Love Autodesk Inventor File Types

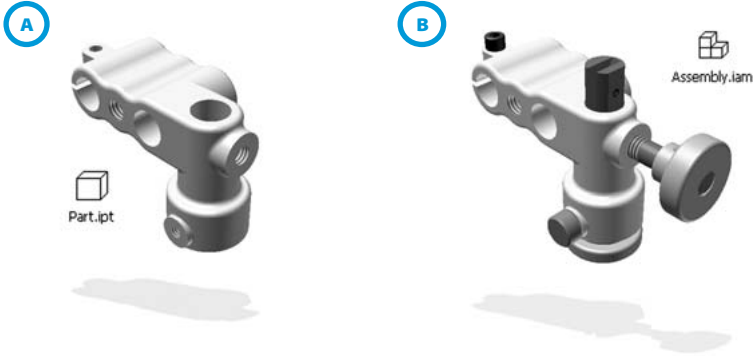

In the world of AutoCAD software, we spend most of our time dealing with just one file type—DWG. Paper space, model space, 2D, and 3D all exist in the same file. The Autodesk Inventor world is quite different in this respect—you'll be dealing with a minimum of four different file types on a regular basis. Your first response to that statement is probably not a good one. How will you keep track of them all?

The good news is that you don't need to—Autodesk Inventor is so smart it does all the work for you. And since these files are all associative, any change you make to one affects all of them. So if you choose to change a component while in an assembly file, the software automatically updates the part file as well as the 2D drawing file. Try not to equate this flexibility to the sometimes frustrating external references in the AutoCAD world—this is a much more sophisticated (and reliable) system. And I'll do my best to help you feel comfortable with each of those four file types by the time you finish Step 3!

A IPT—Inventor Part File

I tend to equate the Autodesk Inventor IPT file to AutoCAD model space. Here you'll create one 2D or 3D part at a scale of 1 to 1. If you choose to create a sheet metal file, you'll also notice the extension is that of an IPT file. Incidentally, Autodesk Inventor has some fantastic tools for creating sheet metal parts and flat patterns! I typically begin drawing in the IPT file.

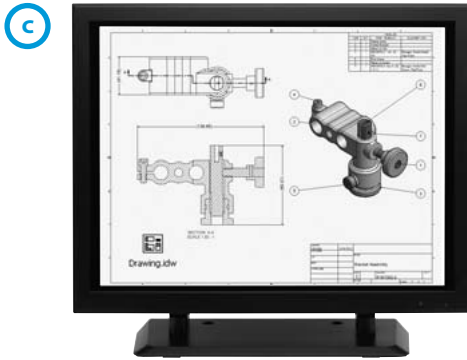

B IAM—Inventor Assembly Model

When you're ready to put multiple parts together into a final assembly you'll create an IAM file. Here you might find a mixture of parts, subassemblies, and assemblies. You can also, however, create part files in the IAM environment. Each part you create is saved to an IPT file.

C IDW—Inventor Drawing File

If the IPT file is equivalent to model space, then the IDW is equivalent to an AutoCAD layout (or paper space). Here you create your final drawing file for output. An IDW file can contain views of parts, assemblies, or presentation files, or all three. It's also super easy to create section views, detail views, and projected views (all of which can be painful in AutoCAD). You'll also find that dimensions and balloons are practically automatic in the IDW.

D IPN—Inventor Presentation File

There's no better way to effectively communicate how parts are assembled or disassembled than in a presentation file. Anyone who has had to write up pages and pages of assembly instructions can appreciate that a picture is worth a thousand words (sometimes literally!). The IPN file is used to effectively display an exploded assembly. By tweaking the various components of the assembly, you can easily create a simple animation that's saved as an AVI file.

Remember that all these files are associated. So if you change a part in an assembly file, Autodesk Inventor automatically knows to apply the update in the part, drawing, and presentation files, thus ensuring that all your files are up-to-date. And it does this without additional input from you!



4

Build a Part: Start with a Sketch

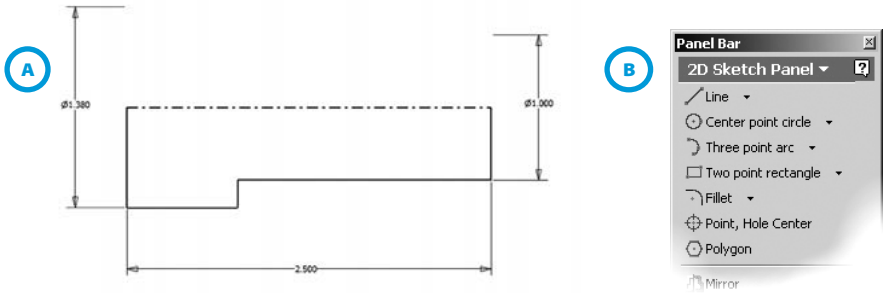

We've got some of the basics down—so now where do we begin?

The process for building parts with Autodesk Inventor is simple:

- Select a plane to sketch on
- Make a sketch
- Constrain the sketch
- Dimension the sketch
- Convert the 2D sketch into a 3D part

That's it. And, believe me, it's just as easy as it sounds.

A Getting Started

It all starts with a simple sketch, just like you've been drawing on a napkin all these years. All sketches must be drawn on a sketch plane (makes sense), and when you start a new part file a sketch plane is automatically set up for you.

The next step is determining the shape for your base sketch. Take a look at the part you want to create and determine the shape that best resembles the overall part. Try to start with a flat face, since they're much easier to work with. After determining your base sketch, you're ready to begin drawing.

B Sketching Made Simple

There are so many great sketching features in Autodesk Inventor there is no way I could possibly cover them all in this booklet—so I'm just going to highlight a few key aspects of the part-building process.

To start off on the right foot, you'll notice that the smart panel bar automatically knows we're in Sketch mode, so the only tools available are those you use to sketch. Here you'll find familiar tools to choose from such as lines, arcs, and circles.

As you start to draw the sketch, you'll find that Autodesk Inventor automatically makes some basic geometric assumptions (known as constraints) such as horizontal/vertical or parallel/perpendicular. Little icons, called glyphs, display, representing the type of constraint that will be added to the geometry. This is similar to working with AutoCAD Ortho mode. As with Ortho, you can turn these constraints off by holding down the Ctrl key. We'll take a closer look at these constraints in the next step.

You'll also see that Autodesk Inventor helps you along by displaying inferred tracking points as dashed lines that work off existing geometry endpoints. This can be compared to AutoCAD object tracking (for those elite few who were able to figure it out!). You may also come across some implied object snaps that help you through the sketching process.

Sketching Made Even Simpler

When you start to sketch, make it easy on yourself by simply approximating the overall size and shape of the base sketch. Later, we'll add some constraints and dimensions to create the exact sketch we're after. And make the sketch simple—the simpler the better. We'll add holes, fillets, chamfers, and more later. You'll also want to make sure that all the endpoints are coincident (meet at the endpoints), with no gaps or overhang.

One last tip—Autodesk Inventor has multiple Undo and Redo. Don't we wish AutoCAD had that!

You'll find the Autodesk Inventor sketching tools are more intuitive and simpler than those in AutoCAD—be sure to try them all!



5

Constrain That Sketch!

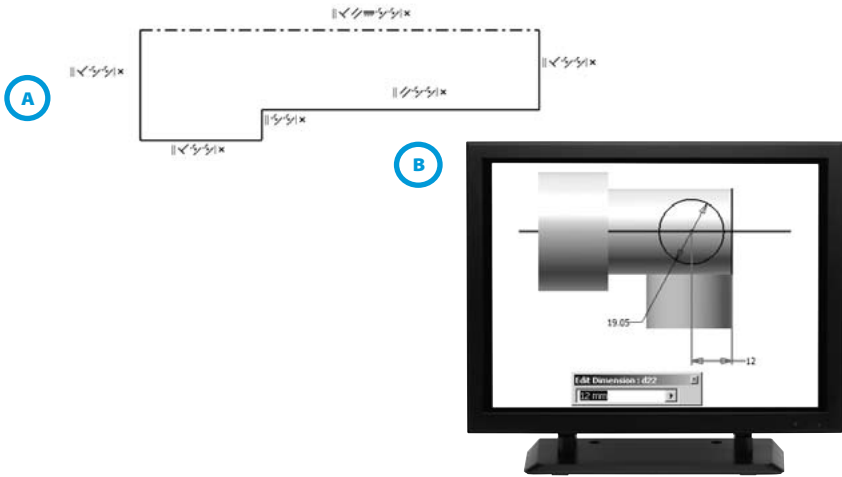

So you've drawn your sketch, and at this point it's probably looking a lot like you've drawn it on a napkin. How do we get it to be the right size and shape? To make sure your sketch has the right size we'll add dimensions, and to ensure the sketch maintains the right shape, we'll add geometric constraints. We're used to working with dimensions in AutoCAD—but what exactly are constraints?

Rules to Live By

Think of constraints as geometric rules by which your sketch must abide. You can place a vertical constraint on a line that forces that line to be vertical regardless of what you do to the sketch. You may tell two circles that they are always to be concentric. You might force a line and an arc always to be tangent to one another. You're essentially setting up a relationship between the various objects in your sketch. Constraints don't stop with sketching—you'll find that you can also place constraints in assemblies to control placement of components, direction of movement, and so on.

After drawing your sketch, you can easily add constraints by selecting them from the Sketch panel bar or by selecting Add Constraints from the right-click shortcut menu.

- A** You can see all existing constraints by selecting the Show Constraints tool from the panel bar. Rows of constraint glyphs (I just love that word!) appear. To delete a constraint, simply select the constraint, right-click to display the shortcut menu, and select the Delete option.

A fully constrained sketch is one that can't move at all (which means that at least one fixed constraint was added). You'll find that a fully constrained sketch turns a darker color. Some people insist on fully constraining their base sketch, some do not—the choice is yours.

B Dimensioning

Dimensioning, technically another form of a constraint, is used to control the size of your sketch. The dimensioning feature in Autodesk Inventor is one of my favorites because it's so easy—you need to use only one dimensioning tool for all your dimensions (imagine that!). Autodesk Inventor is intelligent enough to choose the proper dimension type depending on what you select. Pick General Dimension from the panel bar and select the desired geometry. If for some reason the dimension that appears is not what you were after (for example, Diameter rather than Radius), simply right-click and switch to the desired type. After you place the dimension, the Edit Dimension dialog box appears and you can input the desired value. If the Edit Dimension dialog box doesn't appear, simply double-click on the value to edit it. This is where the real power of Autodesk Inventor begins—you'll find that you can change the size of your sketch at any time just by changing the dimensions.

Objects: A Smart Collection of Sketch Entities

A funny thing happens when you add dimensions to a fully constrained sketch. The addition of the dimensions and constraints turns the lines and arcs in the sketch into a smart object. Now when you make changes to any one entity in the sketch, all of the remaining entities know “exactly” how to update to maintain the implied shape and size.

Autodesk Inventor technology is based on dynamic and associative relationships. A good understanding of constraints is definitely key to your success in Autodesk Inventor!



6

Turn Those 2D Sketches into 3D Parts!

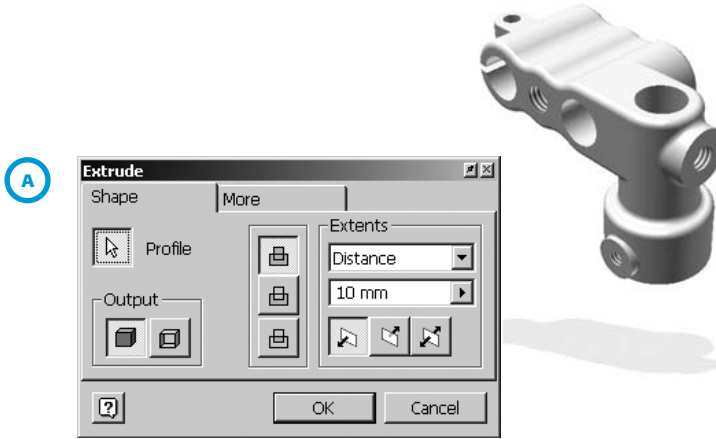

We have our constrained and dimensioned 2D sketch, and now we're ready to make the leap to 3D part modeling. In Autodesk Inventor lingo that means you'll move from Sketch mode to Feature mode. Now you're ready to take your base sketch and turn it into your base feature.

- A** I'd say that 9 times out of 10 you're going to use the Extrude tool first. This tool adds depth to your sketched feature. All the Feature tools have easy-to-follow dialog boxes that dynamically change depending on the input you've provided.

There are two types of features in Autodesk Inventor software—sketched features and placed features. A sketched feature consists of a sketch drawn on a plane (an existing face or a work plane), transformed into a 3D feature by extruding, revolving, sweeping, or lofting it. A placed feature doesn't require a sketch and can be added directly to an existing feature. Fillets, chamfers, and holes are examples of placed features.

In your browser you can find all your features displayed in the order you created them. You can edit them at any time by simply right-clicking on the desired feature and selecting Edit Feature from the shortcut menu. You can even reorder features from the browser.

Taking a Good Look

To survive in 3D you'll need to learn how to control your viewing angle. It won't take you long to realize that you can zoom in and out of the current display by using the wheel on your mouse. (If your mouse doesn't have a

wheel—run out right now and get one that does!) But here's the glitch—in AutoCAD we're used to pushing the wheel forward to zoom in, and pulling the wheel toward us to zoom out. It's the exact opposite in Autodesk Inventor, and this will drive you crazy at first. Think of it like this: as you push the wheel forward, you're pushing the object further away, as you pull the wheel toward you you're pulling the object closer to you. It's an easy adjustment, but it takes a little getting used to.

There are seven different viewing commands on the Standard toolbar. The first two, Zoom All and Zoom Window, work exactly as they do in AutoCAD. The Zoom tool works the same as the wheel on your mouse—as you move your cursor up, the part moves farther away, and vice versa. The fourth tool is Pan (which you are a pro at). This leaves us with three tools that require just a little more explanation.



Zoom Selected: You pick a face and Autodesk Inventor fills the screen with the selected face (or faces).



Rotate: Similar to AutoCAD 3DORBIT, this option dynamically rotates the part. Pressing the space bar while in this mode displays the Glass Box as an additional viewing aid.



Look at: This option changes you to the plan view of the selected face or edge.

More Display Controls

Two function keys are worth mentioning at this point. F4 can also be used to dynamically rotate your part. F5 performs the equivalent of a Zoom Previous. If you press F5 too many times and want to step forward again through your zooms, simply press Shift F5. I use these three options often while designing in Autodesk Inventor (and I wish AutoCAD had the same function key setup!).

Finally, life in Autodesk Inventor would not be complete without the frequently used Isometric View option. It's easy to switch to a standard isometric view by right-clicking and selecting Isometric View. I do this all the time. If you don't like the default isometric view, it's easily changed to a view of your choice.



7

Create a Drawing from the 3D Part

A

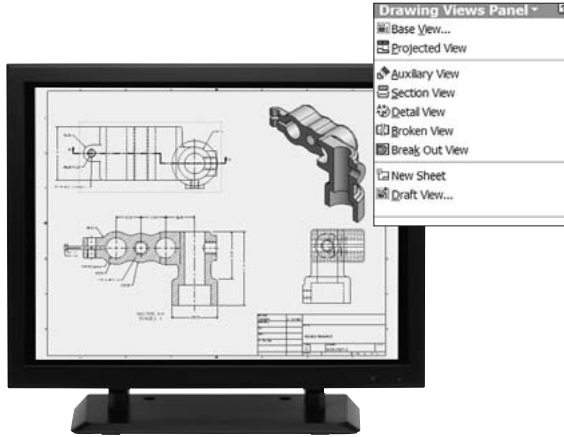

No More Lost in Paper Space

So you've made your part and are ready to create a final 2D drawing with multiple views of your part. You'll want it to contain your title block and border as well as one or more fully dimensioned views. Start by creating a new IDW file. A sheet appears with a default border and title (both of which you can modify to suit your needs). Now we're ready to create our views!

A Base View

Let's start with the base view. Select the Base View tool from the panel bar. Then select the part or assembly file you want to view, along with the scale factor and orientation. Selections you make in the dialog box appear dynamically in the graphics area. Finish by selecting a point in the graphics area to place your view. Now you're ready to create some projected views.

Projected Views

Use the Projected View option to create isometric or orthographic views. You can place multiple views at one time. The process is simple: Select Projected View from the panel bar and pick the base view to work from. The direction you move the mouse controls which projected view appears. Horizontal or vertical movement generates orthographic views, and diagonal creates an isometric view. After placing the various views, right-click and select Create from the shortcut menu.

Section Views

Section views can be painful to create in AutoCAD but are generated instantly in Autodesk Inventor. Simply pick Section View from the panel bar, select the view you want to section, and draw the line that defines the plane that cuts through the part or assembly. Then right-click to continue and complete the Section View dialog box. Complete the command by placing the final view.

Even More Views

Autodesk Inventor supports many different view types, from Detail views to Broken views. All are easily found in the Drawing Views panel bar. Note that you don't need to wait until a part is completed to create your drawing file. Since the Autodesk Inventor files are associative, the drawing file always updates to accommodate the most recent view.

Would you like to grab the dimensions you placed while creating your model? Just right-click in the desired view and pick Get Model Annotations. To add dimensions, right-click in the panel bar to switch to the Drawing Annotations panel bar. Here you'll find the wonderful General Dimension tool we used in Step 5, along with several other dimensioning tools.

Are you worried about layers, text styles, dimension styles, and so forth? No worries—you can duplicate all your familiar AutoCAD settings in the Standards dialog box. There are many drafting standards available for you to use (ANSI, ISO, JIS, and so on), or you can create your own.

If you aren't ready to make that jump to 3D, try creating your 2D drawing in the Autodesk Inventor drawing file. The added intelligence of the Autodesk Inventor parametric-based modeler takes you further and faster than AutoCAD. You can still set up constraints between the views so that if you change the hole in one view, it updates in the corresponding views. It's amazing!

Comparing the IDW to working with AutoCAD paper space layouts doesn't even begin to do it justice. The IDW is exponentially more intelligent, eliminating so much of the tedium we face with paper space layouts.



8

Put It All Together



It's doubtful that you'll spend your life creating solitary parts—more than likely you'll need to combine these parts in an assembly. This takes us to the Autodesk Inventor assembly file (which we now know is the IAM file). The assembly file holds the information necessary to put the parts together.

There are three types of assembly design: bottom-up, top-down, and middle-out. When you insert existing parts and subassemblies in an empty assembly file you're designing from the bottom up. Creating all your components within the assembly space is top-down design. Middle-out assembly design is a combination of the two (and the route you will probably take). There is no right or wrong way to do it; you determine the best method for yourself.

A Bottom-Up Assembly

If possible, insert your components in the order you want the manufacturer to assemble them. The first component should be a fundamental part of the assembly on which the rest of the assembly can be built. The first component you insert becomes the base component, and it is grounded or fixed.

Top-Down Assembly

If you need to create a component while in the assembly mode, simply select the Create Component option from the Assembly panel bar. You'll be asked to select the face or plane you want to work from (just like sketching), and the existing assembly becomes translucent. Don't be fooled; you are still creating a part file (IPT), you're just doing it from inside the assembly file.

B Assembly Constraints

Once you have more than one component in your assembly, you'll want to ensure that they fit together correctly by placing a variety of assembly constraints. For example, a screw fits inside its corresponding hole. If you need to move the hole, you'd like that screw to follow. There are many different types of assembly constraints: Mate, Tangent, and Insert, to name a few. As you add constraints to the components, you'll find that you're reducing their freedom to move.

You can also simulate mechanical motion with the Drive Constraint tool. This allows you to view such motions as a gear being rotated by a pulley, a handle turning, and a piston sliding back and forth. These motion constraints can help you view the overall function of the assembly. Autodesk Inventor can even do interference checking (so you won't get unhappy calls from the shop floor!).

C Adaptive Assembly

As I mentioned earlier, one of the things that differentiates Autodesk Inventor from other 3D modelers is its adaptive technology. Adaptivity allows you to create relationships between parts in an assembly. Once you make a part adaptive, moving or changing adjoining parts forces that part to adapt.

This is just a very quick overview of the Autodesk Inventor assembly modeling functions. There are so many amazing capabilities in the assembly mode that it is difficult to stick with a few of the basics. I especially wish I had time to dive into one of the newest Autodesk Inventor features—weldments. In the weldment assembly environment you can do weld bead specification, weld edge preparation, and postweld machining (ahhh—another booklet, another time!).



9 Put Your AutoCAD Drawings to Work

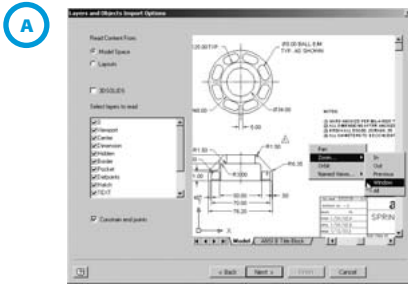

I know, you have all these AutoCAD drawings lying around that you've worked very hard on. Is that data wasted? Absolutely not! Who better to understand all the nuances in translating AutoCAD data than the company that made the product? Autodesk Inventor contains an Import wizard that makes it easy to take designs created in AutoCAD into an Autodesk Inventor part or drawing file. Your 2D data comes in as a sketch, ready to be turned into a 3D part!

A Options, Options, Options

You'll use the Open menu to import AutoCAD drawings into Autodesk Inventor. In the Open dialog box, change the file type to DWG. Now don't jump the gun and hit Open—it's very important that you click the Options button first (in fact, this button should be in bold type in bright red letters so you can't miss it!). We AutoCAD veterans are programmed to ignore additional buttons in the Open dialog box—let this be an exception!

The Options button takes you to the Import wizard. Here you can select the layers you want to translate (as shown in the figure) and set up some basic parameters such as the units and desired destination file type. Be sure the Constrain End Points option is selected; otherwise, you could end up with gaps in your AutoCAD data. You don't want to have to run around tidying up all those unconstrained endpoints! You can also decide whether you'd like your DWG data to land in an Autodesk Inventor drawing or part file. After answering these basic questions, click the Open button.

The associative dimensions you brought in from AutoCAD are not the smart dimensions we have in Autodesk Inventor. Autodesk Inventor automatically migrates the AutoCAD dimensions to the smarter driven dimensions. This raises the IQ on those AutoCAD dimensions and gives them the intelligence we've grown to know and love. Now you can drive your AutoCAD geometry by changing the dimension value—if only it were that easy in AutoCAD!

What About Blocks?

AutoCAD blocks are brought into Autodesk Inventor as sketched symbols (the equivalent of a block). You can then insert additional instances of those symbols into your drawing (much like blocks).

What about your title blocks and borders? Here's a little tip for you—split your title block and border into two different AutoCAD drawing layers. Use the Import wizard twice, bringing the title block in as a Title block and the border in as a Border. That way you won't have to re-create them in Autodesk Inventor.

The Export Wizard

What if you want to go the other way? Perhaps you need to send an Autodesk Inventor drawing to someone who only has AutoCAD. Now you'll turn to the Export wizard.

You can save your Autodesk Inventor file to AutoCAD Release 13 and up. In fact, you can save it as a DXF™ file should you have a client who's still on Release 12. I hear they're still out there!

The Export wizard also enables you to save your Autodesk Inventor objects to specific layer names. You may also choose to associate a specific template file to the drawing.

Autodesk realizes that you have made a huge investment in AutoCAD drawing files and has made it easy to bring this data into Autodesk Inventor.



10

Get into the Autodesk Inventor Groove



You've read the booklet and feel compelled to give Autodesk Inventor a try—where do you go from here? You have several options. Start by contacting your local Autodesk reseller (800-964-6432). Resellers have manufacturing experts on hand who will be happy to guide you to a solution that is just right. If you'd like to try Autodesk Inventor (for free!) before purchasing it, you can request a test-drive CD. Many Autodesk manufacturing resellers offer free seminars where you can see Autodesk Inventor running live.

The only way to purchase Autodesk Inventor is to purchase the Autodesk Inventor® Series. What does that mean? Well, this is the best news yet, because the Autodesk Inventor Series consists of AutoCAD®, AutoCAD® Mechanical, Autodesk® Mechanical Desktop®, and Autodesk Inventor® software! This gives you a chance to learn Autodesk Inventor while you're still using AutoCAD. With all those products built into one package, you're probably thinking it must be very expensive—not so! The Autodesk Inventor Series isn't much more expensive than any one of those products.

Take Some Training

So you've bought the Autodesk Inventor Series; now where do you begin? Though this booklet is enough to get you off the ground, I recommend taking the route I did—enroll for some hands-on training. I took an Autodesk Inventor class from a local Autodesk Authorized Training Center to make sure I had all the fundamentals under control. You'll save lots of time and effort in the long run by learning design and modeling techniques from those who have already spent countless hours using the product.



Explore the Help System

It's fantastic! I used many of the animations in the Design Support System to familiarize myself with the product and occasionally to get me out of a bind (the Constraints animation is my favorite!). We often forget to try the obvious help file while we're learning. Give this one a try. The Autodesk Inventor team considered a robust help file to be a priority, and it really shows!

Read a Book

Even if you take a class, it doesn't hurt to have a good book by your side for reference. There are many good Autodesk Inventor books out there. My personal favorite is *Autodesk Inventor from the Top*. The pages of my copy are dog-eared and highlighted (and you could never get it away from me). You'll find a list of excellent books about Autodesk Inventor in the training and tips section of www.autodesk.com/inventor.

If I've done my job properly, you're now convinced that Autodesk Inventor is not only robust but easy to use. A 3D modeler doesn't have to be complicated to be extremely powerful. Give it a try. I believe you'll never want to go back to AutoCAD again!

The Autodesk logo, consisting of the word "autodesk" in a lowercase, sans-serif font. The "a" is blue, and the "utodesk" is black. A registered trademark symbol (®) is located at the top right of the "k".

autodesk®

Autodesk, Inc.

111 McInnis Parkway
San Rafael, CA 94903
USA

Autodesk, AutoCAD, Autodesk Inventor, Mechanical Desktop, and DXF are either registered trademarks or trademarks of Autodesk, Inc., in the USA and/or other countries. All other brand names, product names, or trademarks belong to their respective holders.

© Copyright 2002 Autodesk, Inc. All rights reserved.

000000000000112864

